

DRAWING #: D00723
REV: A

REVISION HISTORY				
ZONE	REV	DESCRIPTION	DATE	APPROVED
	A	INITIAL RELEASE		

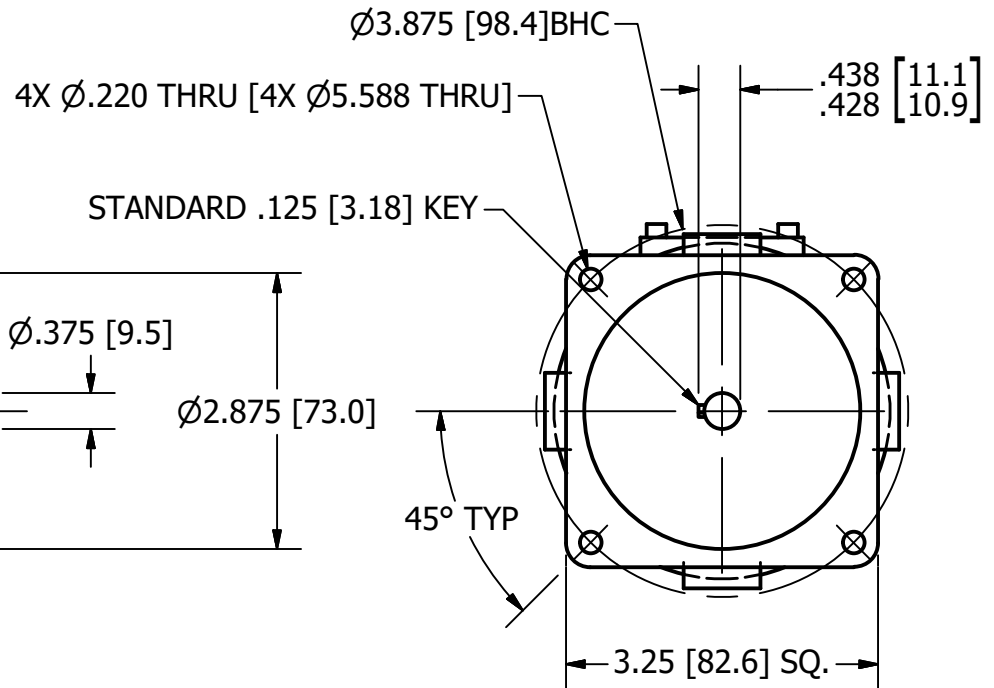

TOLERANCES:
X ± 0.025 0° ± 30'
XX ± 0.010 0.0° ± 3'
XXX ± 0.005
XXXX ± 0.0005

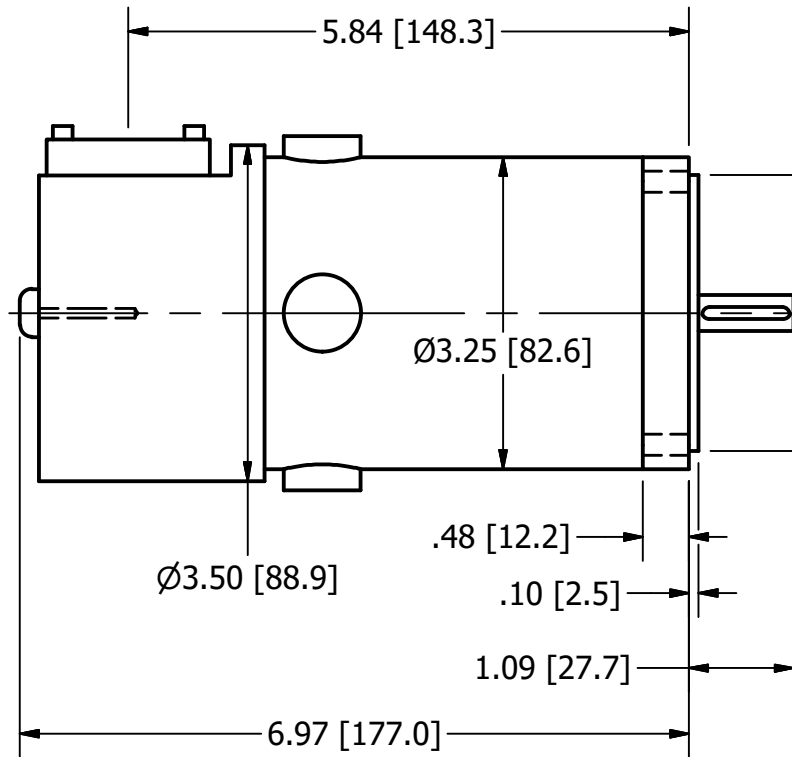
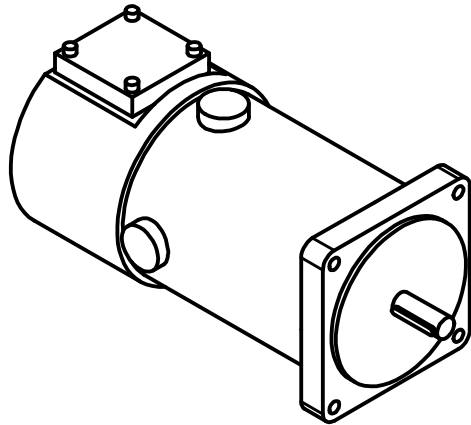
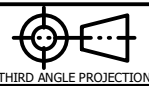

PROPRIETARY AND CONFIDENTIAL
THE INFORMATION CONTAINED IN THIS DOCUMENT IS THE SOLE PROPERTY OF CENTROID CORPORATION™. ANY REPRODUCTION AS A WHOLE OR IN PART WITHOUT THE EXPRESS WRITTEN PERMISSION OF CENTROID CORPORATION™ IS STRICTLY FORBIDDEN.



ASSEMBLY:		TITLE: MOTOR, SERVO, DC, 10 inlb		
PRODUCT:		MATERIAL:	FINISH:	
DRAWN: GRH	APPROVED:	BARCODE:	PART #:	DRAWING #: D00723
SIZE: A		WEIGHT: N/A	SCALE:	REV: A
©2016 CENTROID			SHEET #: 1 OF 1	