

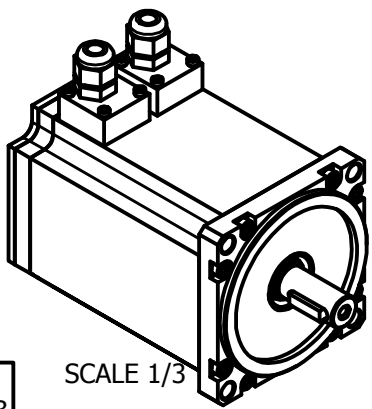

DWG #: D00175 REV: A

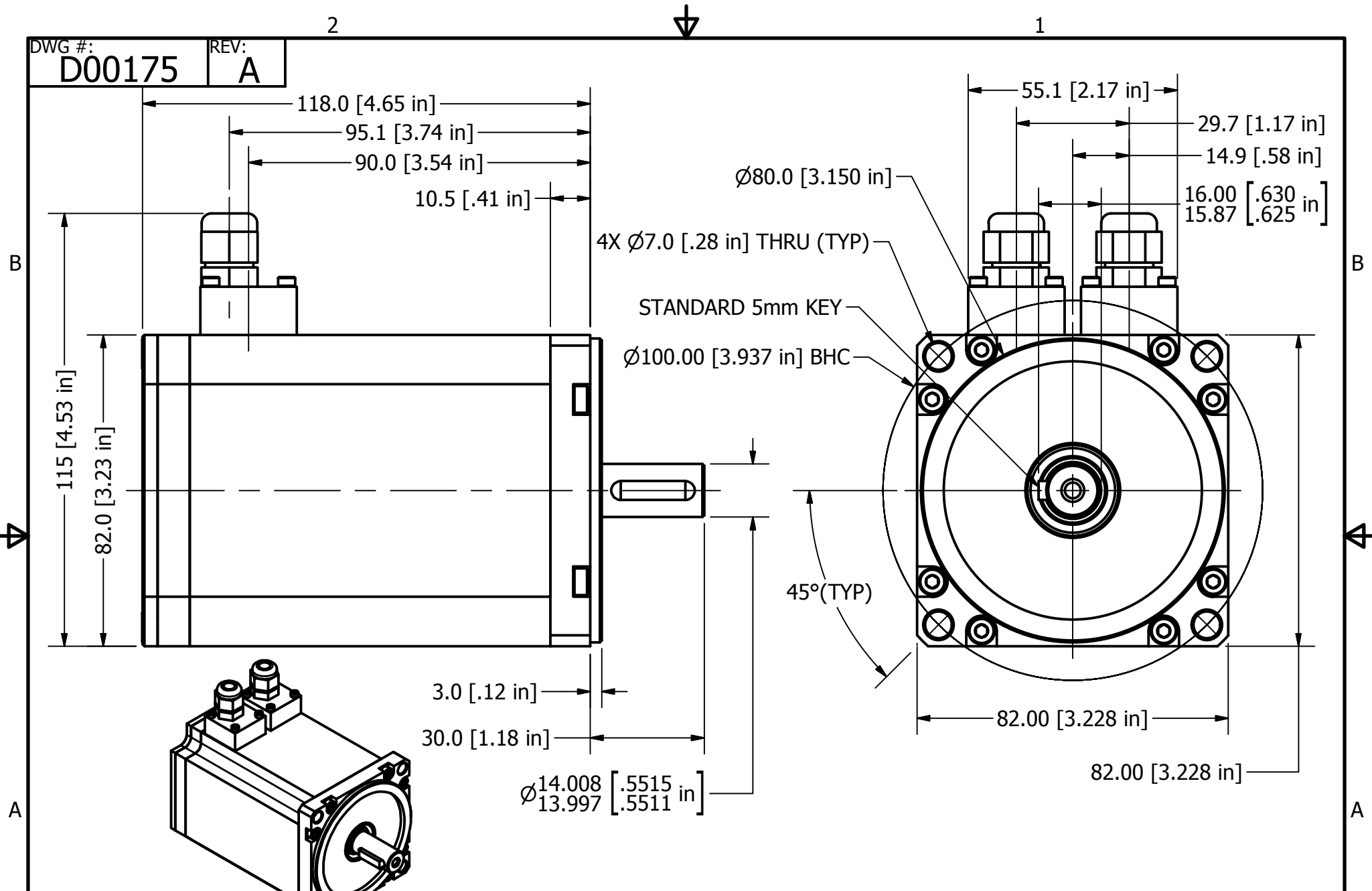

SCALE 1/3

DATE
DRAWN: 10.17.13

NOTES:
1. PART# 11093 COPYRIGHT CENTROID CORP

 <p>CENTROID T:(814)353-9290 F:(814)353-9265 www.CENTROIDCNC.com</p>	TOLERANCES	X	± 0.025	0' ± 30'	TITLE:	750W AC SERVO MOTOR	DRAWN:	SZP
	UNLESS	XX	± 0.010	0.0' ± 3'	FINISH:	NA	APPROVED:	RPE
	OTHERWISE	XXX	± 0.005		MATERIAL:	NA	DWG #:	D00175
	SPECIFIED:	XXXX	± 0.0005		SCALE:	3/4	REV:	A